

**LANA Example 1 : Open-Ended Inquiry Tasks**  
Explore The Linear-Algebraic Nodal Analysis (LANA) Algorithm  
on a Circuit with 7 Resistors, 3 Voltage Sources, 3 Current Sources

### LANA Example 1: Ideal schematic diagram

Figure 1 provides an ideal circuit diagram for an electric circuit that includes seven  $1\text{k}\Omega$  resistors, three dc voltage sources, and three dc current sources. In this diagram, we label and enumerate each ideal circuit element and assign associated values.

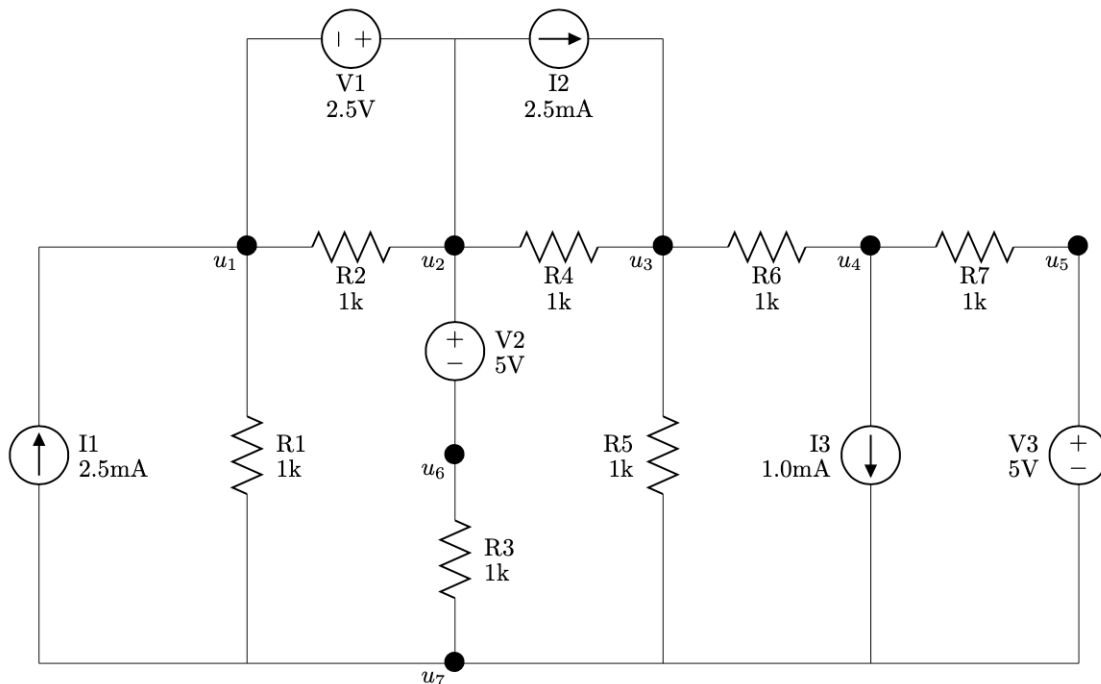

Figure 1: An ideal schematic diagram of a circuit containing seven resistors, three dc voltage sources, and three dc current sources.

### Open-Ended Inquiry Tasks

1. Use the LANA algorithm to find the values of all node voltage potentials in the circuit. Verify your solutions via some other method. For example, you might:
  - A. Simulate the circuit with Computer-Aided Design (CAD) software ([MultiSim](#) is a good option).
  - B. [Prototype this circuit](#) on a breadboard and make measurements with a digital multimeter
2. Use vector  $\mathbf{u}_g$  from the LANA algorithm to solve for all other circuit variables:
  - A. Find all entries of the vector  $\mathbf{v}_r$  for the voltage drops across the resistors.
  - B. Find all entries of the vector  $\mathbf{v}_i$  for the voltage drops across the current sources.
  - C. Find all entries of the vector  $\mathbf{i}_r$  for the currents running through the resistors.
  - D. Find all entries of the vector  $\mathbf{i}_v$  for the currents running through the voltage sources.
  - E. Using the values for all entries of the current vector  $\mathbf{i}$ , analyze the flow of currents in your circuit. Then draw a directed graph model for the current flow in the entire network. What do you notice?

3. Make sense of and interpret the entries of all matrices used in this model:
  - A. What do the individual entries of matrix  $K$  represent?
  - B. What does the vector  $\mathbf{f} = A_i^T \mathbf{i}_i$  represent?
  - C. What does the vector  $\mathbf{b} = -A_{r_g} \mathbf{p}_g$  represent?
  - D. Why is the process of melding all nodes within each generalized node equivalent to multiplying the entire resistor subblock  $A_{r_g}$  on the right by the matrix  $Z_{v_g}$ ?
  - E. How is the matrix  $A_r = A_{r_g} Z$  related to the deactivated resistor network? What information about the circuit can you read from  $A_r$ ? What information is missing from this matrix?
4. Make sense of each entry in the various matrix equations from a physics or engineering perspective:
  - A. KCL equations:  $A_g^T \mathbf{i} = \mathbf{0}$ .
  - B. BCR equations:  $\mathbf{i}_r = G \mathbf{v}_r$ .
  - C. KVL Equations:  $A_g \mathbf{u}_g = \mathbf{v}$ .
  - D. How are the entries of these equations related to knowledge you are building in your other classes?
5. Play with the LANA algorithm. Explore each step slowly and deliberately.
  - A. What happens if you switch the assigned reference directions for the resistors in your circuit? How does this change the structure of the matrix  $K$ ?
  - B. Change the values of the power sources and re-run your algorithm. Which parts of the equilibrium equation change and which remain the same? Why?
  - C. Change the values of the resistors in the circuit and re-run your algorithm. Which parts of the equilibrium equation change and which remain the same? Why?
  - D. What happens if you switch your choice of free variables? How many different options do you have for this example circuit? How many options do you have for a general circuit? What do those options depend on?
  - E. What happens if you switch your choice of ground node? How many options do you have?
  - F. What if you want to ground a node that was not part of your chosen free variables? What changes would you have to make in your approach to this algorithm?
  - G. How many different nonsingular linear-systems problems can you generate using the LANA algorithm applied to a single circuit diagram? What are the relationships between the solutions to your various systems? Can you get one solution from the other? If so, how? If not, why not?
6. Make sense of the proof that the columns of  $Z_{v_g}$  form a basis for the null space of  $A_{v_g}$ .
7. Make sense of the proof that the matrix  $K = A_r^T G A_r$  is nonsingular.
8. Design your own circuit example. You can use circuits that you've seen in other classes or be creative. Then analyze your circuit using LANA and compare your favorite circuit simulator.
9. How can you make the matrix  $K$  singular? What features of a circuit would have to be present for the nonsingularity proof in LANA to fail? Design a circuit that produces a singular matrix  $K$ . How can you adapt your approach to apply LANA if you encounter such a circuit in the wild?
10. Write a MATLAB script file that produces the proper result for any resistor network with dc voltage and current sources.
11. What happens if you reverse the order in which you eliminate the constraints. In other words, what if you were to first eliminate the ground node and then eliminate the voltage source constraints? Can you still get to the end result by switching the order in which you eliminate variables?

12. How would you measure total system energy? As you think about this, ponder what happens when you take the dot product between  $v$  and  $i$ . What output do you get? How is that output related to the conservation of energy? How is this related to Tellegen's Theorem?
13. How many unique proofs can you create to show that the matrix  $K$  arising in the LANA algorithm is nonsingular?
14. How might you extend the LANA algorithm to deal with dependent power sources?
15. How might you adapt the LANA algorithm to run AC analysis on RCL circuits?